

Description:	ROCK CRAWLER SIDE BAR TO SUIT 2015+ NISSAN NAVARA
Model:	Navara/2015
Item NO.:	SSSRA-NAVARA15

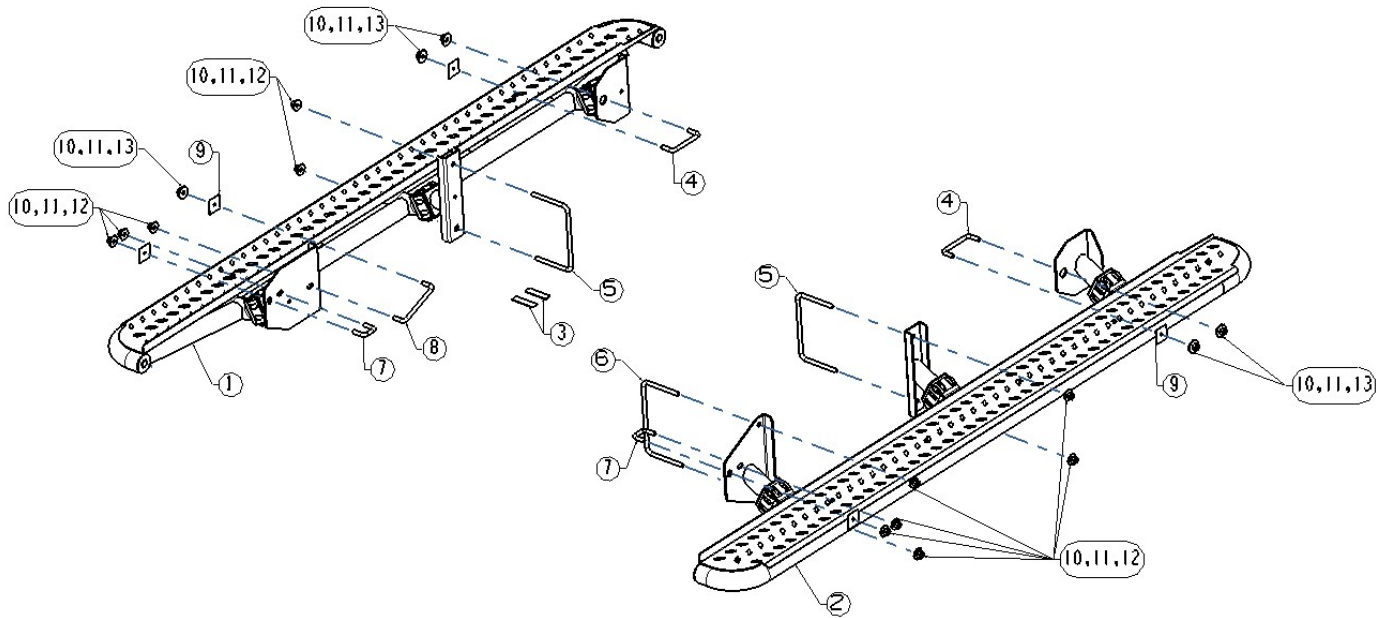



---

## Note:

: PLEASE READ BEFORE ATTEMPTING INSTALLATION.

- All Rockarmor products are manufactured to highest of standards and latest finishes including sand blasting all raw material and e coating to clear the product of any impurities and finished with a tiger coat to keep the longevity if at any stage while off road or on road use this product is damaged or scratched have the damaged surface repaired.
- This product and its fixings must not be modified in any way unless stated in this fitting instruction.
- Do not remove labels from this product.
- Do not use this product for any vehicle other than specified in these instructions.
- It is the installer's responsibility to assure this product is installed correctly allowing enough tolerance for movement between the chassis and body and clearance of all components.
- Use Loctite on all nuts and bolts.
- The installation of this product may require the use of specialized tools and or trained fitter.

The following tools will be required to install the product.

Metric Socket Set 10-18MM.

Metric Spanner Set 10-18MM.

Torx Drivers T25-T30

Trim Removal Tool

Screwdriver Set (Flat and Phillips head)

Utility Knife

Side Cutters

Pliers

Loctite

---







Standard locking torque

M6 - 11Nm | M8 - 18Nm | M10 - 80 Nm | M12 - 90 Nm | M16 - 90 Nm

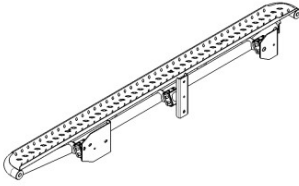
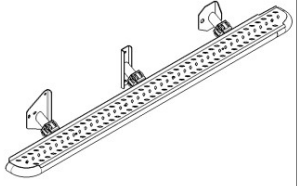
---

### Material list

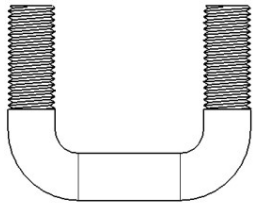
Item	item NO.	Description	Qty	Item	item NO.	Description	Qty
Part list							

1	R280005673	 Side bar assemble (L)	1	2	R280005695	 Side bar assemble (R)	1
3			2	4	R280005713	 U-bolt (centre distance: 100, total height:41, length of thread 22)	2
5	R280005714	 U-bolt (centre distance 183, total height 120, length of thread 70)	2	6	R280005715	 U-bolt (centre distance 203, total height 120, length of thread 70)	1
7	R280005716	 U-bolt (centre distance 41.5, total height 41, length of thread 22)	2	8	R280006682	 U-bolt (centre distance 123, total height 40, length of thread 22)	1
<b>Hardware kit</b>							
Item	Item NO.	Description					Qty
9	TY000506	PVC plastic fixture block $\phi 10(60.7*40*40)$					5
10	3001491	Hexagon nut M10					16

11	3000155	Spring washer D10	16
12	3000245	Washer D10(10x30x2.5mm)	11
13	3000421	Washer D10(10x34x3mm)	5

## Installation Steps: FRONT BRACKET

— Install front bracket use below kits:

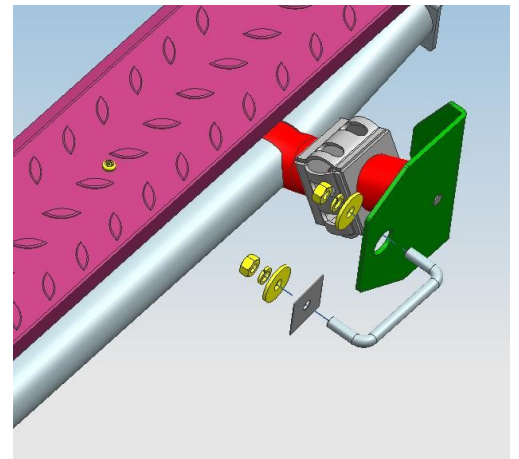
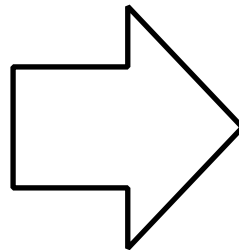
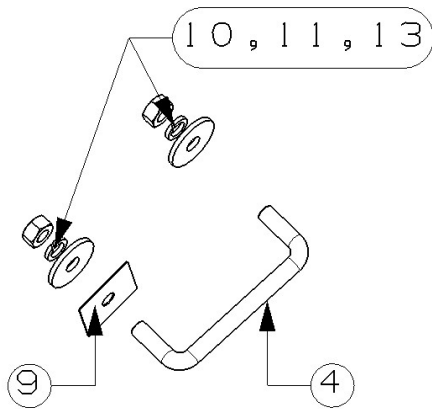

Item 4: E280005713- U-bolt

Item 9: TY000506- PVC plastic fixture block $\phi$ 10( $\delta$ 0.7\*40\*40)

Item 10: 3001491- Hexagon nut M10

Item 11:3000155- Spring washer D10

X  
1  
X  
1  
X  
2  
X  
2

Item 13:3000421-Washer D10(10x34x3mm)

## CENTRE bracket uses below kits:

Item 5: E280005714- U-bolt

Item 10:3001491- Hexagon nut M10

Item 11:3000155-Spring washer D10

Item 12:3000245-Wahser D10(10x30x2.5mm)

X  
2  
X  
2  
X  
2

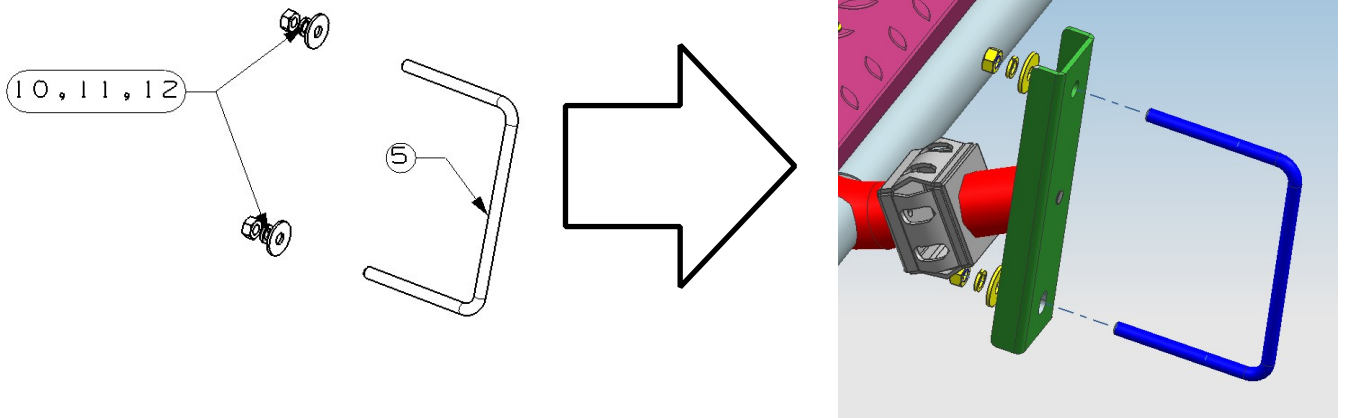

Install rear bracket (LH) use below kits:

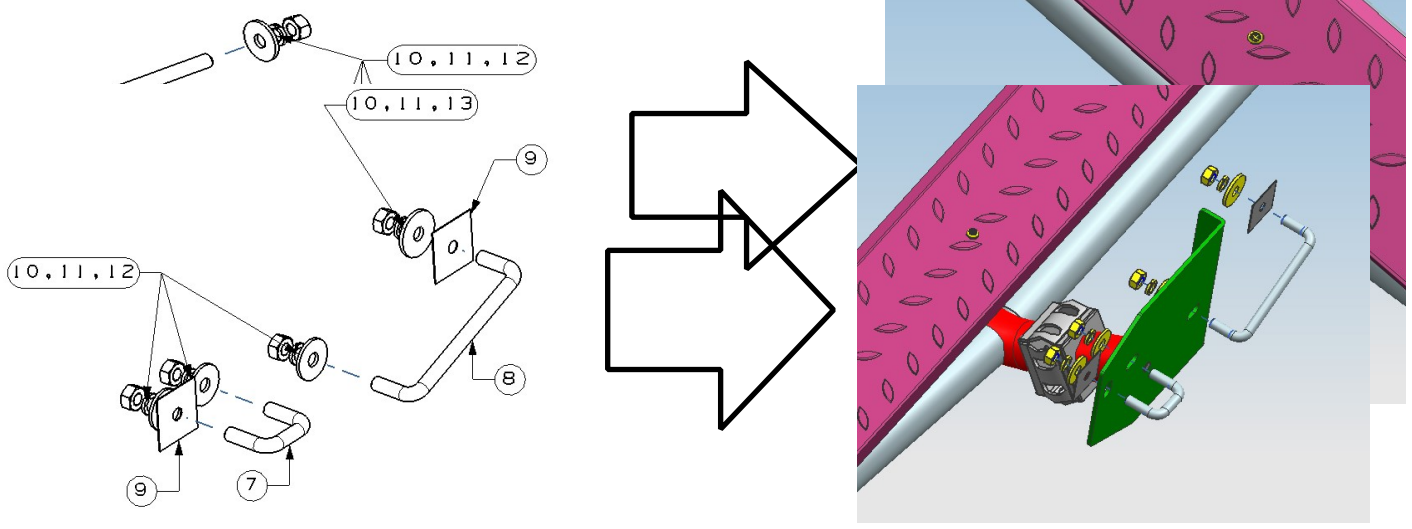

Item7:E280005716- U-bolt	X1
Item8:E280006682-U-bolt	X1
Item9: PVC plastic fixture block $\phi$ 10( $\delta$ 0.7*40*40)	X2
Item10:3001491- Hexagon nut M10	X4
Item11:3000155- Spring washer D10	X4

em12:3000245-Washer D10(10x30x2.5mm) Item13:3000421-  
Washer D10(10x34x3mm)

## 二. Install rear bracket (RH) & need use below kits:

Item7:E280005716-U-bolt

Item6:E280005715-U-bolt

X

Item9:TY000506- PVC plastic fixture block $\phi$ 10( $\delta$ 0.7\*40\*40)

1

Item10:3001491- Hexagon nut M10

X

1

X

4

Item11:3000155- Spring washer D10

Item12:3000245- Washer D10(10x30x2.5mm)

**For more information check out [www.rockarmor.com.au](http://www.rockarmor.com.au) and watch our YouTube installation video.**