

Fitting Instructions



SKU

UNT369

PRODUCT

**Towbar Wiring Harness
for Mitsubishi Triton MV
(02/2024 - on)**

SPECIFICATIONS

- Approx. Fitment Time: 45 Minutes
- Dealer Coding Required: No
- RPA override: Yes
- Plug & Play: Yes



Scan for latest
version of these
instructions

TOOLS REQUIRED

- Spanners
- Side Cutters
- Screw Drivers
- Trim Removal Tool

IN THIS GUIDE

- Fitment Instructions
- Warnings
- Warranty Info

Important Information



Warning:

- This unit is designed to bypass the electronic control module in the vehicle.
- This unit will not require dealer coding.
- The vehicle has a 30 Amp dedicated trailer fuse in the engine bay fuse box. This must be swapped out with a 10 Amp fuse.
- **THE 10AMP FUSE MUST NEVER BE REMOVED AND CANNOT BE CHANGED FOR A HIGHER AMP FUSE.**
- Make sure to inform the customer that there is a 10-amp blade fuse in the engine bay fuse box , in the event the fuse needs to be replaced. **Kindly show them where they can access it.**
- Please give this copy of the instructions to your customer.
- Contact an authorised TAG distributor or the TAG fitment center - (07) 3208 3022 - if further information is required.

7 Pin Flat Plug & Socket

PIN No.	CIRCUIT	COLOUR
1	Left-hand turn	Yellow
2	Reversing signal	Black
3	Earth return	White
4	Right-hand turn	Green
5	Service brakes	Blue
6	Stop lamps	Red
7	Rear lamps, clearance & side marker lamps	Brown



7 Pin Plug



7 Pin Socket

Step 1: Install Wiring Harness

1. Open the bonnet and disconnect the negative terminal of the battery.



2. Lower the spare wheel and put aside.
3. Open the tailgate & remove 2x Phillips head screws securing each of the tail light assemblies.
4. Remove taillights, disconnect from their connectors and put aside.



Installation Instructions



Step 1: Cont'd

5. In each of the tail light cavities, use a trim tool to dislodge the clips (2 places) securing the tail light harnesses onto the body.
6. Pull the tail light harness through the panel hole to the outside of the vehicle.



Trailer Harness Layout:

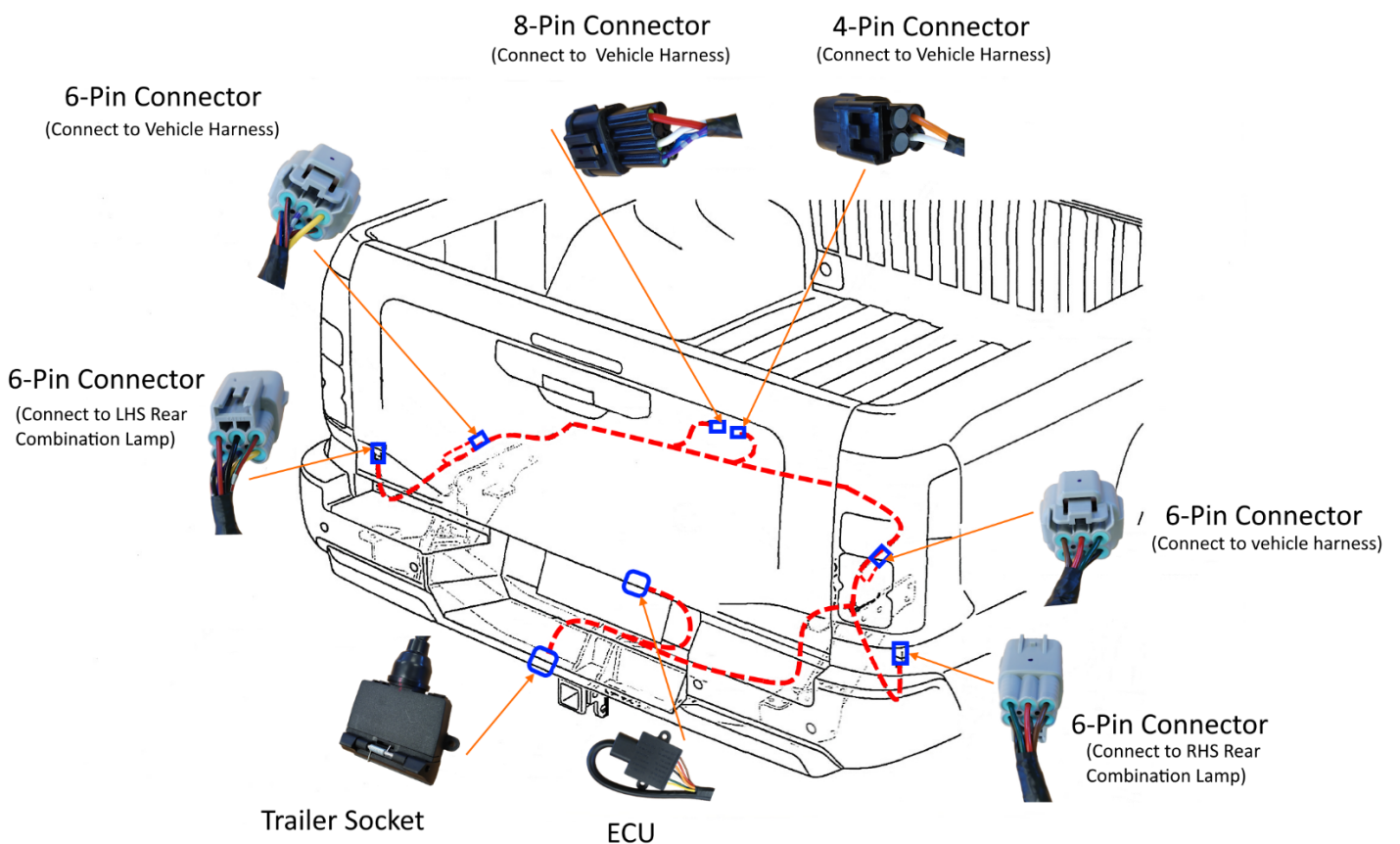

Installation Instructions



7. On the underside of the vehicle, above the chassis rails, roughly route the harness based on the layout diagram, on the previous page. Follow the existing vehicle harness and ensure the RHS labeled branches are on the drivers side and the LHS labeled branches are on the Passengers side.

Caution: When routing the harness, care must be exercised to prevent the trailer harness and the vehicle harness from getting caught, interfering with sharp & moving objects and sources of heat.

8. Unclip the tail light harnesses from the chassis rail to get more length to work with.



9. On the LHS (Passenger Side), connect the Towbar Harness Female 6-Pin connector to the tail light connector which was pulled through in Step 6.

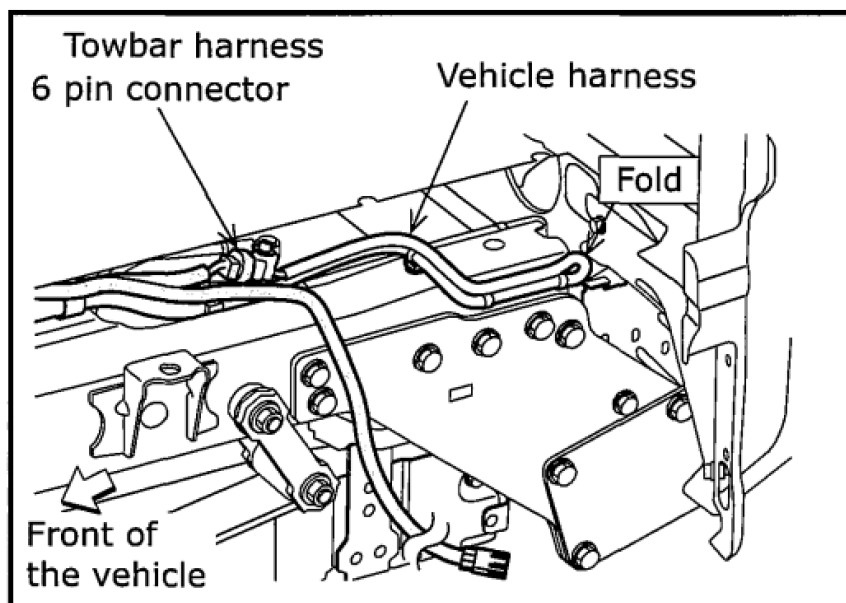

Installation Instructions



10. Route the trailer harness Male 6-Pin Connector through the tail light cavity panel hole and connect the clip to the vehicle body.

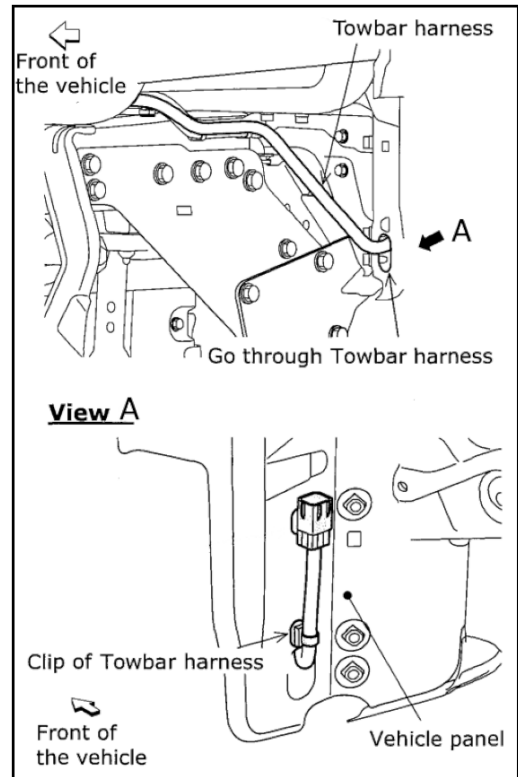
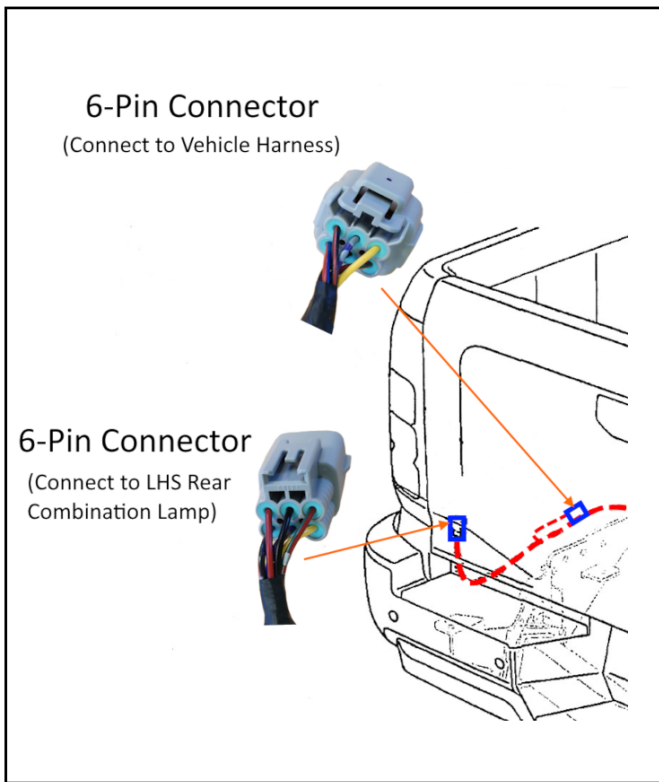

11. Repeat steps 9 & 10 on the RHS (Drivers Side)
12. On the rear chassis cross-member, locate the position of the 8-Pin & 4-Pin vehicle harness connectors.
13. Remove the tape on the spare connectors and remove the blanking caps.

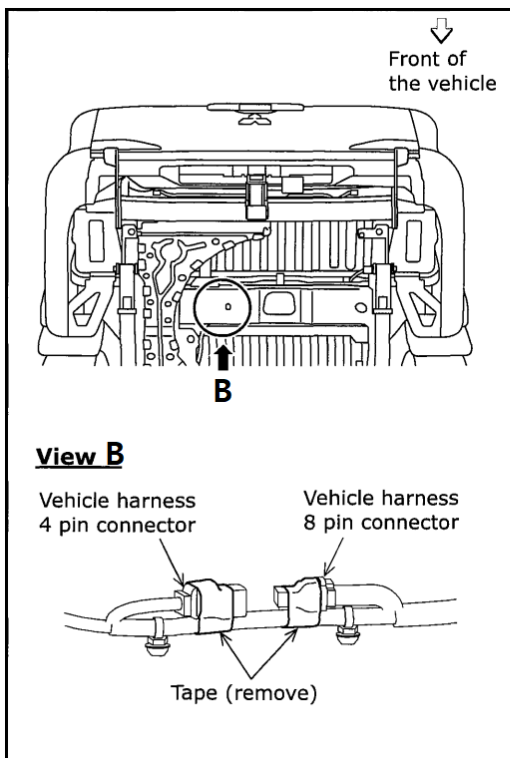

Installation Instructions



14. Connect the 8-Pin & 4-Pin trailer harness connectors to the corresponding vehicle harness connectors.

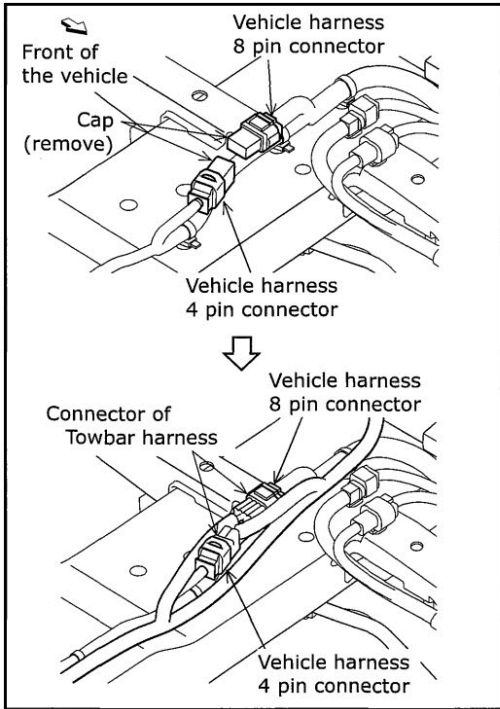

15. Mount and fasten the 7-Pin flat trailer socket onto the plug mount of the towbar using the supplied fasteners.

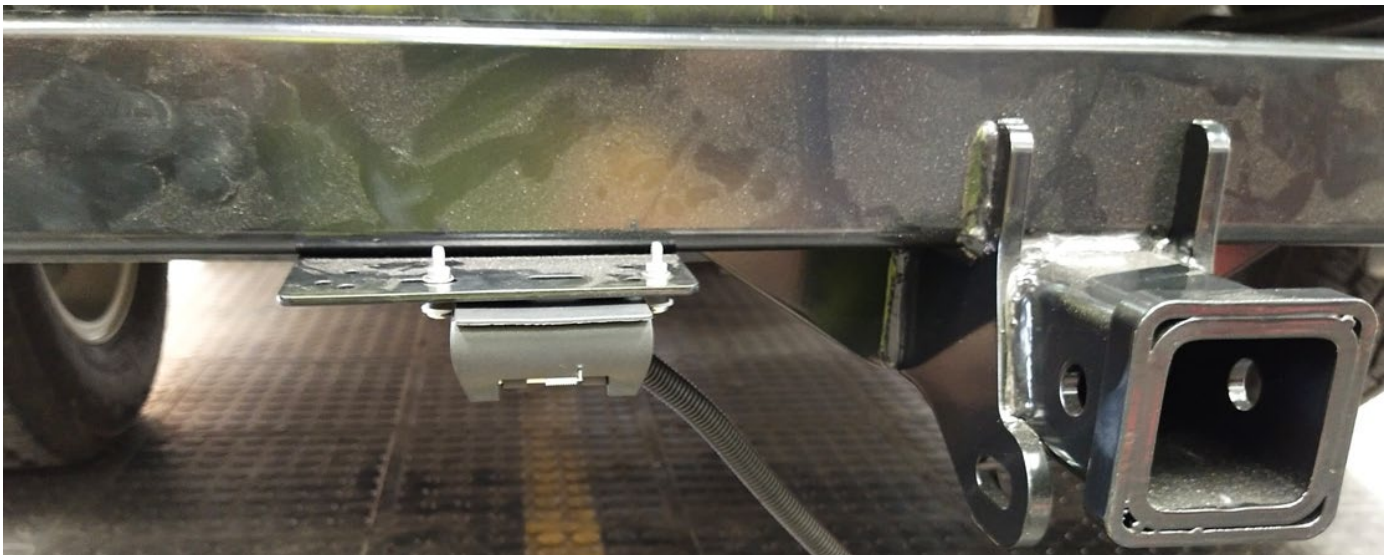

Installation Instructions



16. Mount the ECU on a rib of the tray body or chassis rail using the supplied double sided tape and cable ties. Tek screws (not supplied) can also be used to screw into the tray body rib.

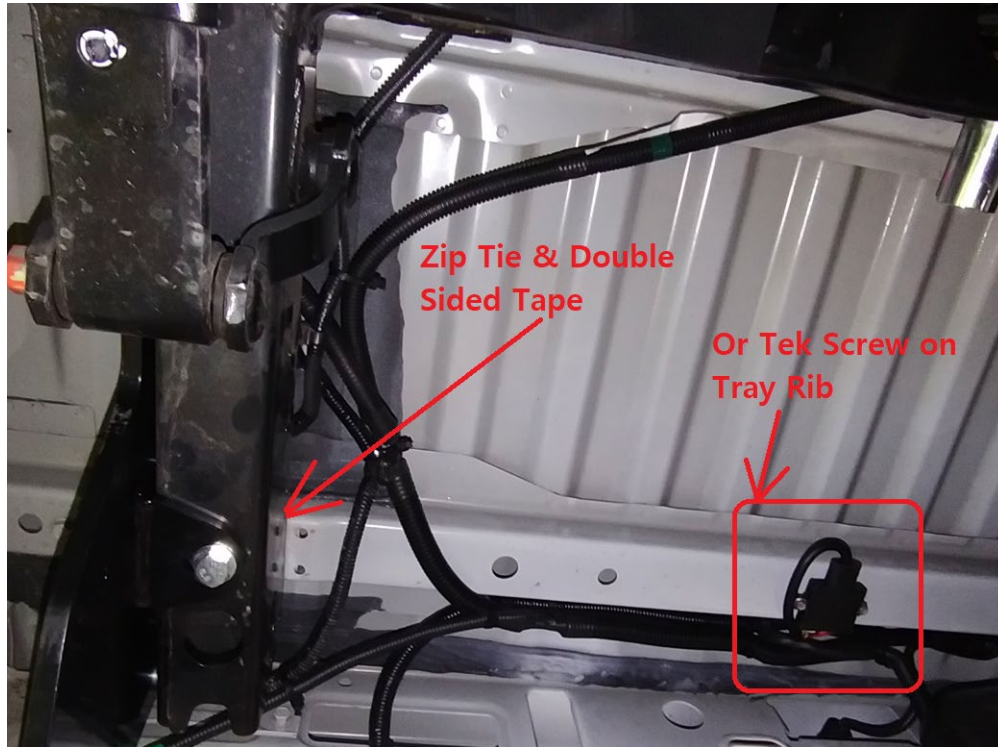

17. In the engine bay, locate the Fuse Box. Open the cover and locate the trailer fuse on the layout diagram on the underside of the cover.
18. Replace the 30A (or 20A) fuse with the supplied 10A Fuse. **A 10 Amp fuse must be installed.**
19. Reinstall the fuse box cover.

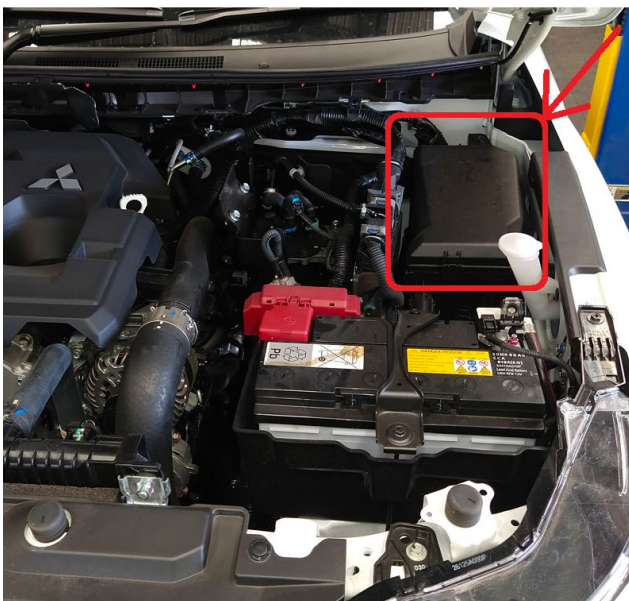

Installation Instructions



Must be replaced with a 10 Amp fuse!!!

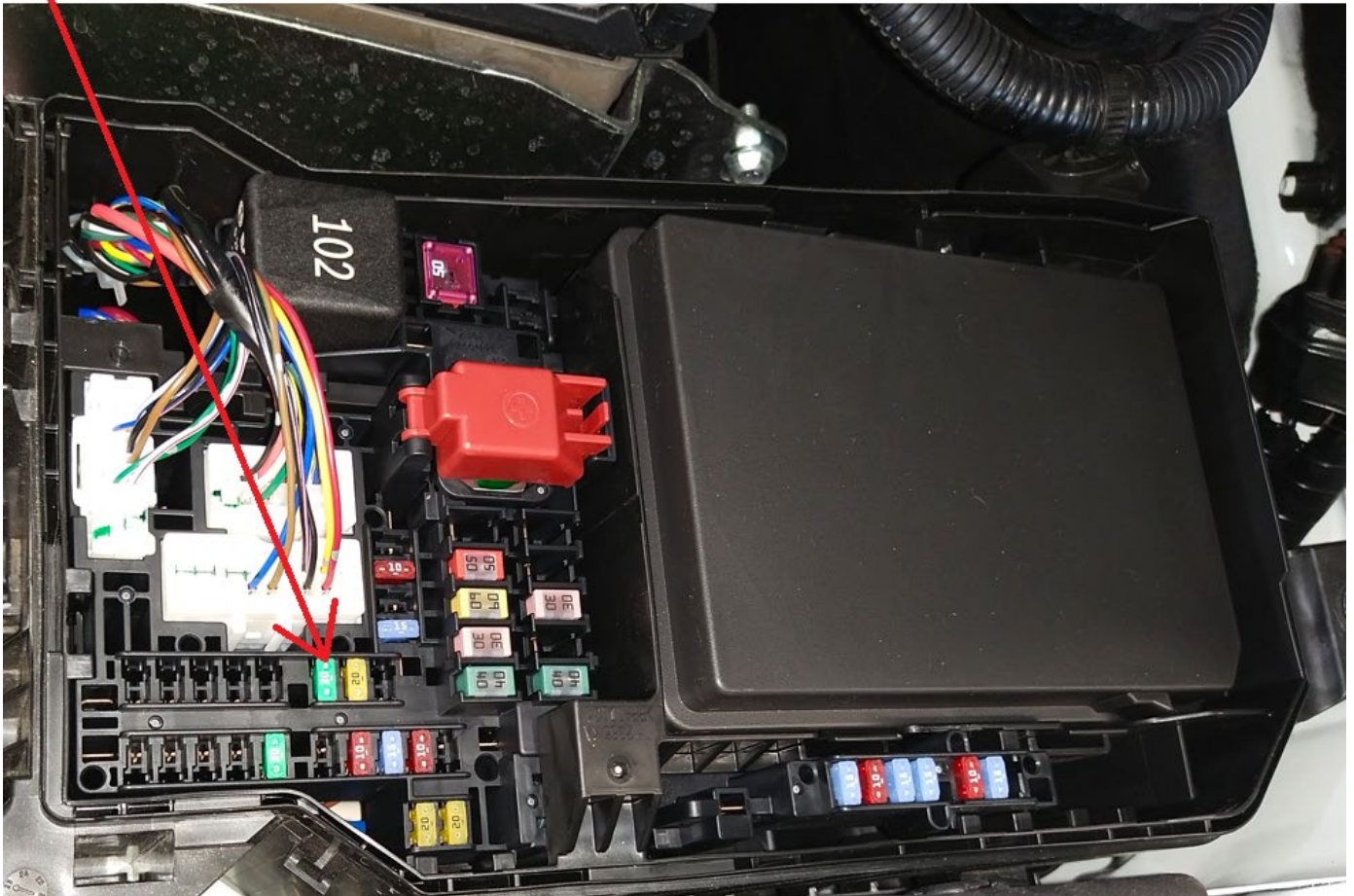

20. Ensure all connectors are securely connected.
21. Reconnect Rear Tail Lights.
22. Reconnect the battery negative terminal.
23. Test the Harness using a test board or multi-meter.
24. Using cable ties (not included) secure the trailer harness to the chassis rails and existing harness at least every 200mm.

Caution: When routing the harness, care must be exercised to prevent the trailer harness and the vehicle harness from getting caught, interfering with sharp and moving parts and sources of heat.

Place these instructions in the vehicle glove box and notify the customer about the 10 Amp fuse. This fuse must never be replaced with a higher rated fuse.

TAG Warranty Statement



SWD warrants your TAG Harness for its full product life under the following conditions:

- You can show proof of purchase.
- The harness has been correctly installed by a suitably qualified installer.
- The harness has not been modified or abused in any way and has only been used for the purpose intended.
- The harness was not fitted second hand to your vehicle.

The extent of this warranty includes materials and workmanship used in the manufacture of the harness and is to the equivalent value of current, full replacement cost.

Nothing stated or implied in this warranty limits in any way, the statutory rights that you may have.

To make a claim visit the original installer in the first instance or, if you are unable to or are not satisfied with their help, then contact us direct by phone on 1300 669122 or visit www.swd.com.au.