

# ROCKARMOR Fitting instruction

Description:	GT Bull Bar to Suit 2018+ Toyota Prado
Model:	2018+ Toyota Prado
Item NO.:	BBRA-150GT



## Note:

- 1) This bull bar cannot be installed onto other vehicles, in addition to the manufacturer special instructions
- 2) Do not remove label on the bar.
- 3) Do not change the structure of bull bar.

## Standard locking torque

M6 - 11Nm | M8 - 18Nm | M10 - 80 Nm | M12 - 90 Nm | M16 - 90 Nm

# ROCKARMOR Fitting instruction

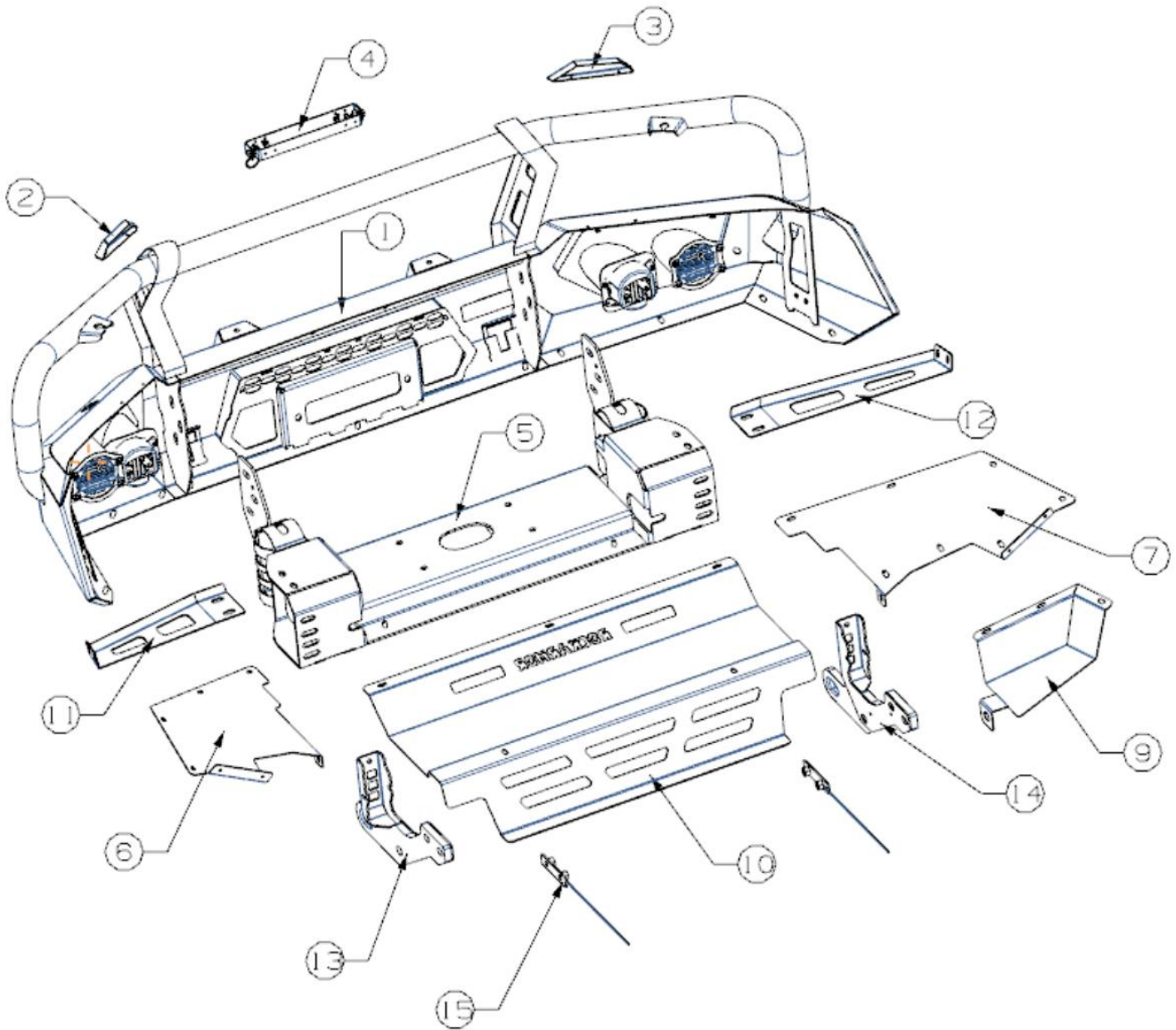

## PLEASE READ BEFORE INSTALLATION

- All Rockarmor products are manufactured to highest of standards and latest finishes including sand blasting all raw material and e coating to clear the product of any impurities and finished with a tiger coat to keep the longevity if at any stage while off road or on road use this product is damaged or scratched have the damaged surface repaired.
- This product and its fixings must not be modified in any way unless stated in this fitting instruction.
- Do not remove labels from this product.
- Do not use this product for any vehicle other than specified in these instructions.
- It is the installer's responsibility to assure this product is installed correctly allowing enough tolerance for movement between the chassis and body and clearance of all components.
- Use Loctite on all nuts and bolts.
- The installation of this product may require the use of specialized tools and or trained fitter.

# **ROCKARMOR** Fitting instruction

The following tools will be required to install the product.

Metric Socket Set 10-18MM.  
Socket Extension Bar  
Metric Spanner Set 10-18MM.  
Torx Drivers T25-T30  
Trim Removal Tool  
Screwdriver Set (Flat and Phillips head)  
Utility Knife  
Side Cutters  
Pliers  
Impact Drill  
Loctite  
Cable Ties  
Masking Tape  
Satin Black Automotive Paint  
Grease and wax Remover  
Scotch Brite or Fine sandpaper

- For more information regarding this product please visit [www.Rockarmor.com.au](http://www.Rockarmor.com.au)

# ROCKARMOR Fitting instruction

## BILL OF MATERIAL List

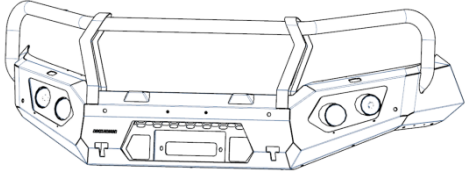
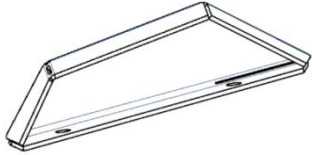
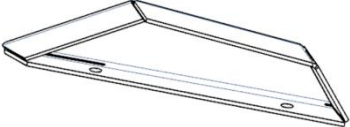
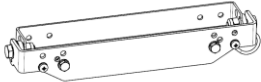
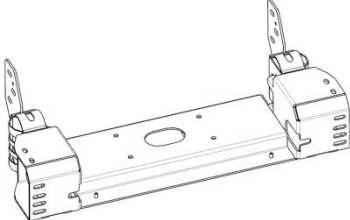
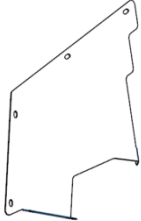
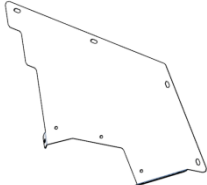
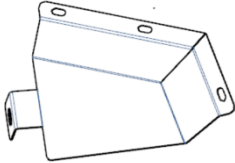
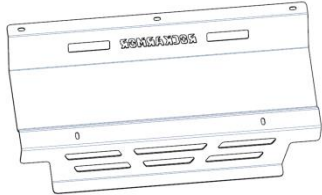
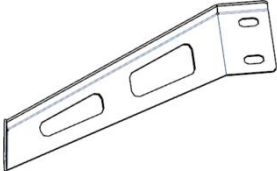
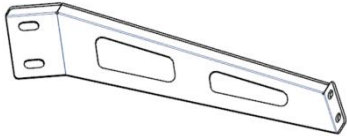
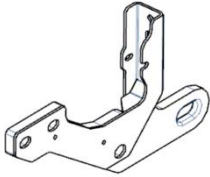
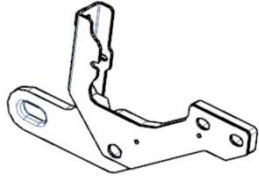
Item	Description	Qty	Item	Description	Qty
1	 Bull bar assemble	1	2	 Grill Cover (LH)	1
3	 Grill Cover(RH)	1	4	 License Plate Holder	1
5	 Winch Frame	1	6	 Bash plate 1(LH)	1
7	 Bash plate 2(RH)	1	8		
9	 Bash plate 3(RH)	1	10	 Centre bash plate	1
11	 Bull bar Holder(LH)	1	12	 Bull bar Holder(RH)	1
13	 Outside Bracket(LH)	1	14	 Outside Bracket(RH)	1

# ROCKARMOR Fitting instruction

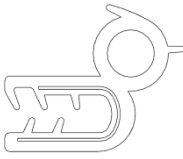
15	 Outside Bracket Holder	2	N/A	 Pinch mold (2400mm)	1
----	---	---	-----	--	---

Item	Description	Qty
16	Flange Nut M6	10
17	Hexagonal head bolt M10x30	4
18	Hexagonal head bolt M10x40	2
19	Hexagonal head bolt M12x40	6
20	Hexagonal head bolt M6x16	4
21	Hexagonal head bolt M6x20	26
22	Hexagonal head bolt M8x25	2
23	Hexagonal head bolt M10x1.25x30	4
24	Hexagonal head bolt M10x1.25x35	8
25	Hexagonal head bolt M12x1.25x45	6
26	Hexagonal head Nut M10x1.5	4
27	Hexagonal head Nut M12x1.75	6
28	Flange Nut M10x1.25	4
29	Lock Nut M10x1.5	2
30	D10x30_2 Washer	6
31	D12x37_3 Washer	18
32	D6x18_2 Washer	30
33	D8x24_2 Washer	2
34	Spring Washer D10	12
35	Spring Washer D12	12
36	Spring Washer D6	30
37	Spring Washer D8	2
38	D10x24_2 Washer	18

# **ROCKARMOR** Fitting instruction

---

## 1. Installation Steps:

Remove front surround

Remove the front body panel, as shown in the picture below

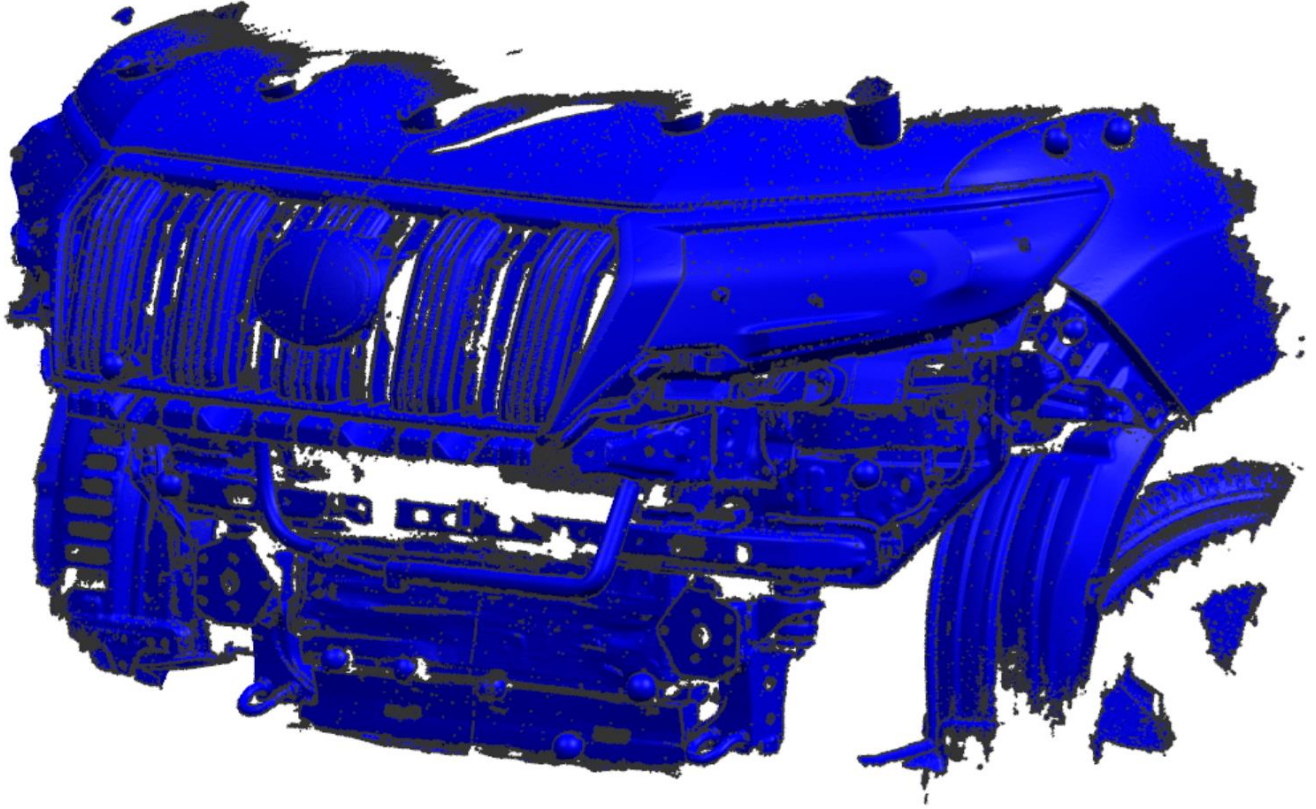

# ROCKARMOR Fitting instruction

## 2. Chassis Mount: item 13&14&15(LHS) Fit Recovery Points left and Right side

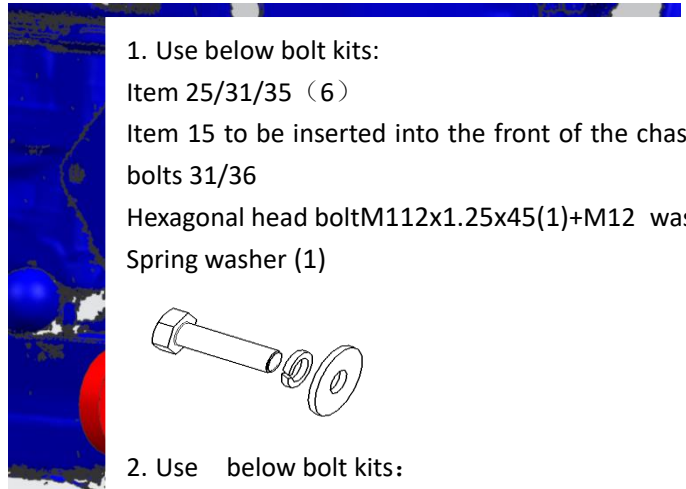
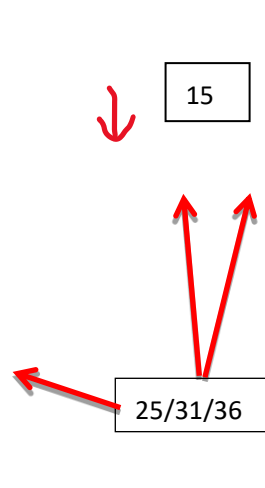

1. Use below bolt kits:

Item 25/31/35 (6)

Item 15 to be inserted into the front of the chassis to secure bolts 31/36

Hexagonal head bolt M112x1.25x45(1)+M12 washer(1)+M12 Spring washer (1)

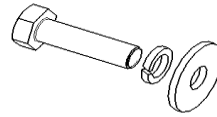

2. Use below bolt kits:

Item 22/33/37 (2)

Hexagonal head bolt M18x25(1)+M8 washer(1)+M8 Spring washer(1)

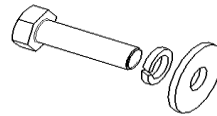

## 3. install item 5 Fit Winch Frame to The Front Of The Vehicle.

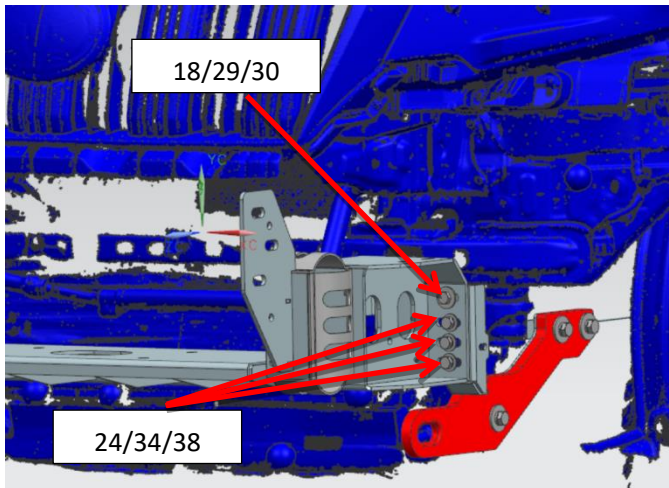

1. Use below bolt kits:

Item 18/29/30 (2)

Hexagonal head bolt M10x40 (1)+M10 washer(2)+ Lock Nut M10x1.5 (1)

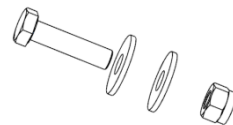

2. Use below bolt kits:

Item 24/34/38/4 (6)

Hexagonal head bolt M10x1.25x35 +M10 Spring washer+M10 x24 washer

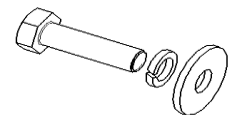

# ROCKARMOR Fitting instruction

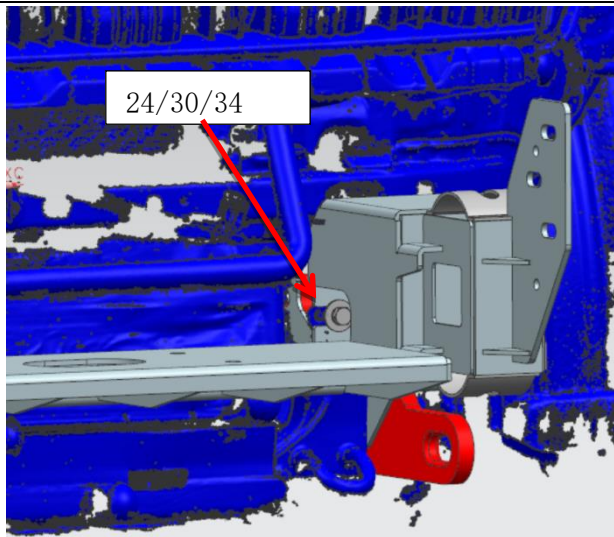

1. Use below bolt kits:

Item 24/30/34 (2)

Hexagonal head bolt M10x1.25x35 +M10 Spring washer+ M10 washe

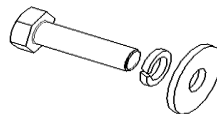

Note: If Fitting A Winch, It Is To Be Installed At This stage.

## 4. Install item 10 2&3(LHS)

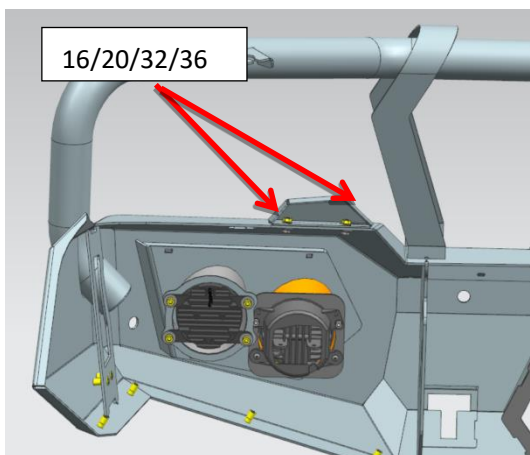

Need use below bolt kits:

Item16/20/32/36 (4)

Hexagonal head bolt M6x16 + Flange Nut M6 + D6x18\_2 Washer +Spring Washer D6



Install Sensors / Washer Jets / Pinch Weld / Wiring at this stage.

## 5. Install item 1 Bull Bar Mounting

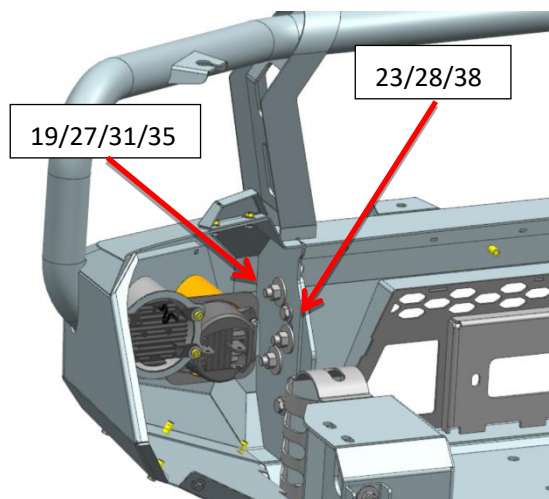

Use below bolt kits: Mount the Bull Bar to the cradle, Allow enough gap for flex before tightening (15mm is recommended).

1. Item 19/27/31/35 (6)

Hexagonal head bolt M12x40(1) + Hexagonal head Nut M12x1.75(1) + D12x37\_3 Washer(2) + Spring Washer D12(1)



2. Item 23/28/38 (4)

Drill out Location holes (Paint Holes)and use hexagonal head bolt M10x1.25x30 + Flange Nut M10x1.25 + D10x24\_2 Washer





# ROCKARMOR Fitting instruction

## 6. Install item 11&12 Wing Support Brackets

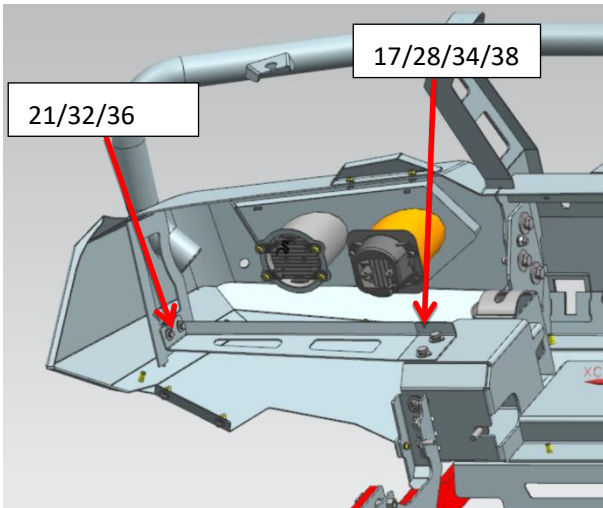

use below bolt kits: To Install the wing support brackets

3. Item 21/32/36 (19)

Hexagonal head bolt M6x20+D6x18\_2 Washer+Spring Washer D6

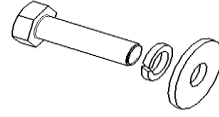

4. Item 17/28/34/38 (4)

5. Hexagonal head bolt M10x30(1) + Hexagonal head Nut M10x1.5(1)  
+ D10x24\_2 Washer(2) + Spring Washer D10(1)

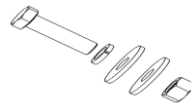

## 7. Install item 6&7&9&10 Mount Underbody Protection Plates

## 8. Trim The Inner Guards to mount with protection plates.

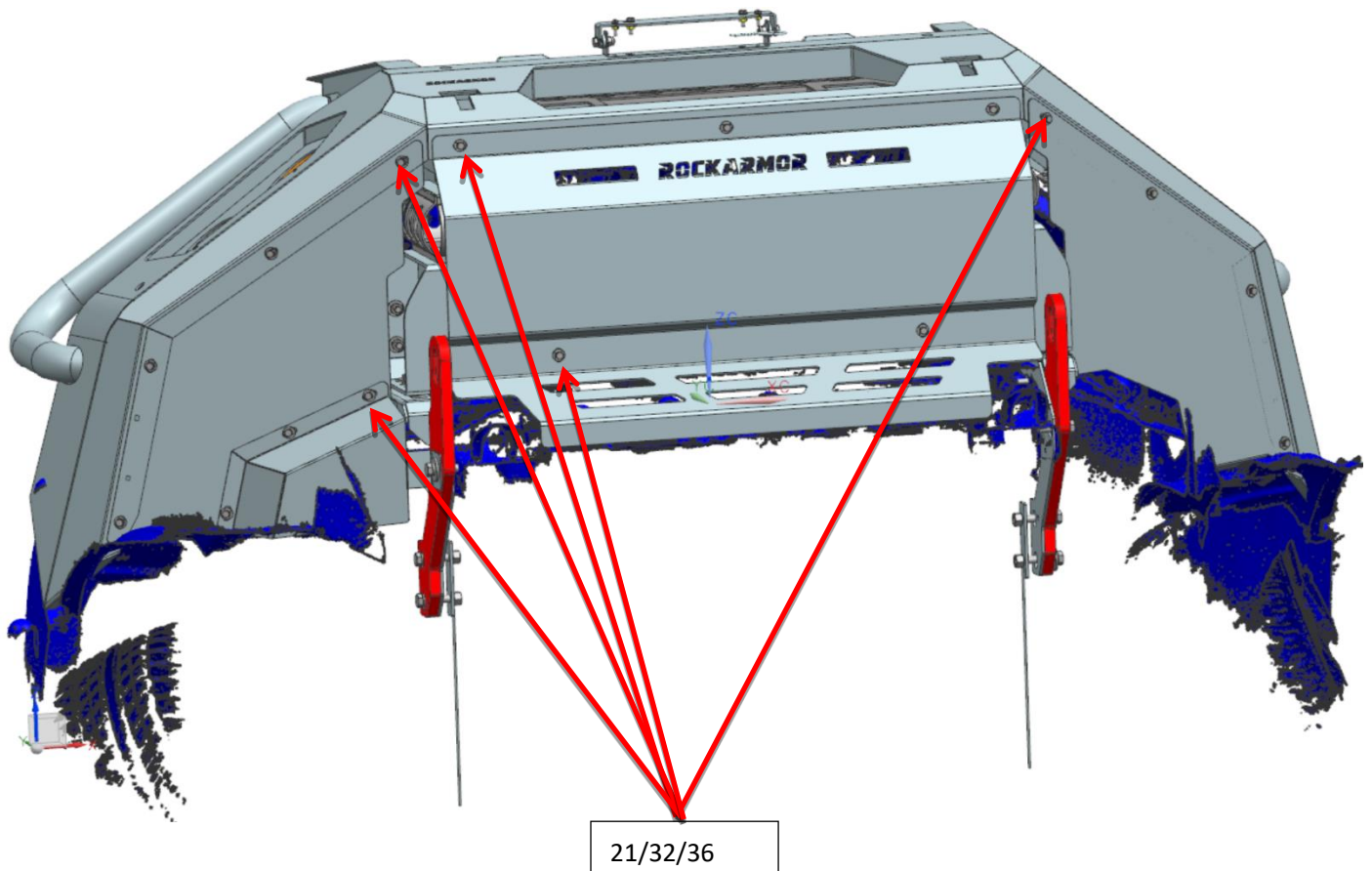

# ROCKARMOR Fitting instruction

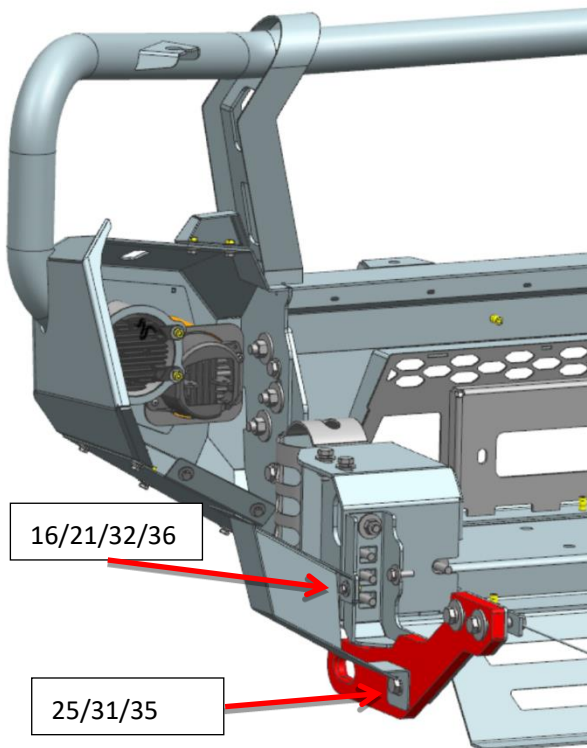

## 9. install item 4: Install Foldable Number Plate Holder

Use below bolt kits: To Install washer Bottle Cover.

1. Item 21/32/36 (16)

Hexagonal head bolt M6x20+D6x18\_2 Washer+Spring Washer D6

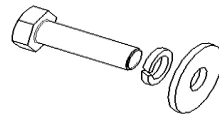

2. Item 16/21/32/36 (2)

Hexagonal head bolt M6x20+D6x18\_2 Washer+Spring Washer D6+ Flange Nut M6



3. Item 25/31/35 (2)

Hexagonal head bolt M12 x1.25 x45+ D12x37\_3 Washer +Spring Washer D12

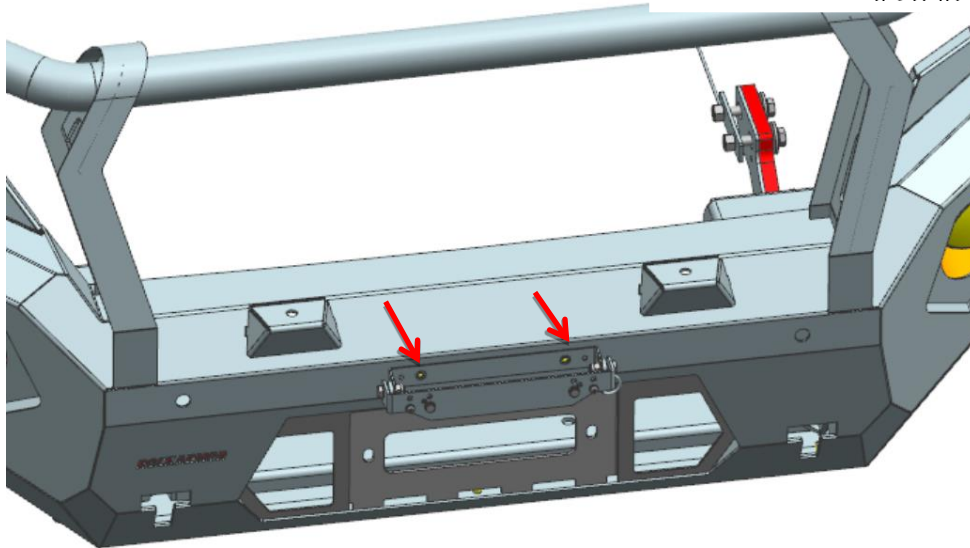

Need use below bolt kits:

Hexagonal head bolt M6x20+D6x12\_2 Washer



# **ROCKARMOR** Fitting instruction

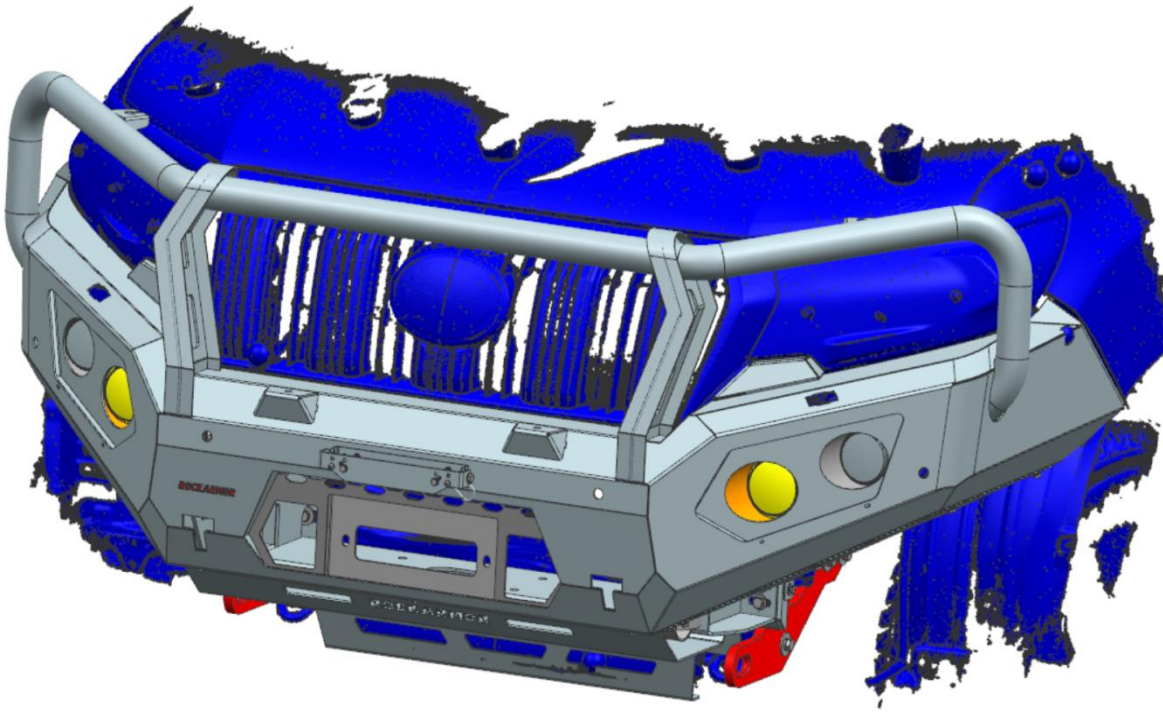

For more information check out [www.rockarmor.com.au](http://www.rockarmor.com.au) and watch our YouTube installation video.